**PHUSE50-XL-N** [↗](#)

Take-up housing unit

Take-up housing units PHUSE, cast iron and sheet steel housing, radial insert ball bearing with eccentric locking collar, P seals

X-life

Technical information

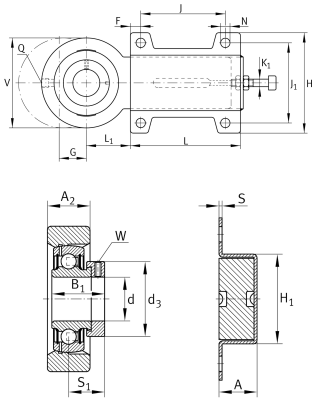

Your current product variant

Groove	N	Cast iron housing with undercut slot for end caps
Material	GG	Grey cast iron

Main Dimensions & Performance Data

d	50 mm	Bore diameter
H	130 mm	Height flange
A	36 mm	Height housing
V	120 mm	Shoulder diameter housing
L	256 mm	Length total
C _{0r} G	23.200 N	Load carrying capacity (housing)
≈m	5,299 kg	Weight

Mounting dimensions

N	14 mm	Fixing bore
J	180 mm	Distance fixing bore
J ₁	100 mm	Bore distance width



Dimensions

L ₁	60 mm	Distance shaft axis
A ₂	30 mm	Width housing
H ₁	60 mm	Height guidance
K ₁	M16	Thread adjusting screw
S	4 mm	Thickness of flange
F	20 mm	Distance fixing bore outside
G	80 mm	Axial displacement
Q	M6	Connection thread for lubrication

Additional information

HUE10	Housing
HUSE10	Housing (Part 2)
GRAE50-XL-NPP-B	Bearing designation
KASK10	Protecting cap

Temperature range

T _{min}	-20 °C	Operating temperature min.
T _{max}	120 °C	Operating temperature max.