**KRE19-PP**

Stud type track roller

Stud type track rollers KRE...-PP-A, single row needle roller bearings with particularly thick-walled outer ring, needle roller and cage assembly and a solid roller stud with fixing thread and a mounting aid, axial guidance of outer ring is provided by the plastic axial plain washers, contact flange and contact washer, three-stage sealing by plastic axial plain washer on both sides, with eccentric collar

Technical information

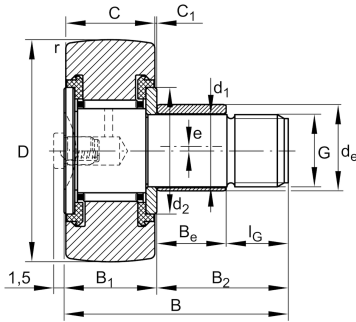

Your current product variant

Sealing	PP	Three-stage sealing by plastic axial plain washer on both sides
Outer ring profile	IOP	Optimized INA-profile
Grease nipples	1x	Drive-fit lubrication nipple unmounted 1x
Assembling aid head	SL	Mounting slot

Main Dimensions & Performance Data

D	19 mm	Outside diameter
d ₁	8 mm	Fit diameter of roller stud / stud
B	32 mm	Width
C _{r w}	3.550 N	Basic dynamic load rating, radial
C _{0 r w}	4.100 N	Basic static load rating, radial
C _{u r w}	560 N	Fatigue load limit, radial
n _{D G}	11.000 1/min	Speed on permanent grease lubrication
≈m	31,01 g	Weight



Dimensions

B ₁	12,2 mm	Width of thrust washer
B ₂	20 mm	Bolt/stud length effectively
C	11 mm	Width, outer ring
C ₁	0,6 mm	Protrusion outer ring to thrust washer
r _{min}	0,15 mm	Minimum chamfer dimension
d ₂	15 mm	Stop diameter of thrust washer
G	M8	Thread
l _G	10 mm	Thread length
d _e	11 mm	Diameter of eccentric
B _e	9 mm	Width, eccentric
e	0,5 mm	Eccentricity

Additional information

	NIPA1	Drive-fit lubrication nipple
	1,5 mm	Protrusion lubrication nipple
M _A	8 Nm	Tightening torque nut

Characteristics



Radial load



Lifetime lubrication, freedom from maintenance



Grease Lubrication



Sealed on both sides