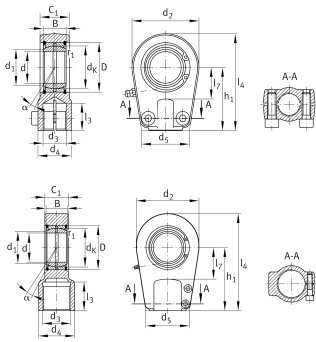
**GIHRK60-DO** [↗](#)

Rod end

Hydraulic rod end, with thread clamping device, right hand thread, requiring maintenance, sliding contact surface: steel/steel, open design

Technical information

**Your current product variant**

Clampable	Clampable
Maintenance	Maintenance required
Lubrication nipple	DIN71412-AS6 (tapered grease nipple)
Slotted	Slotted, both sides
Thread Pitch	Right-hand thread
Sealing	Without
Mounting	Internal thread clampable
Radial internal clearance	CN (Group N) Normal internal clearance

Main Dimensions & Performance Data

C_r	318.000 N	Basic dynamic load rating, radial
C_{0r}	327.000 N	Basic static load rating, radial
d	60 mm	Bore diameter bearing
d_2	130 mm	Outer eye diameter
l_4	200 mm	Total length internal thread head
D	90 mm	Outside diameter bearing
B	44 mm	Width inner ring
$\approx m$	5,621 kg	Weight



Dimensions

α	6 °	Tilt angle
C ₁	50 mm	Width of the rod end
d _K	80 mm	Ball diameter
d ₃	M58x1,5	Thread size
d ₄	75 mm	Shank diameter
d ₅	90 mm	Shank diameter, large
d ₇	M10x45	Diameter screw clamp
h ₁	130 mm	Shank Length Internal thread head
l ₃	59 mm	Thread length Internal thread
l ₇	65 mm	Distance drilling with/shaft start
d _{UT}	-0,015 mm	Bore diameter bearing, lower tolerance
d _{OT}	0 mm	Bore diameter bearing, upper tolerance
B _{UT}	-0,15 mm	Width inner ring, lower tolerance
B _{OT}	0 mm	Width inner ring, upper tolerance
M _A	46 Nm	Tightening torque
G _r	0,043 - 0,12	Radial Clearance
G _{rmin}	0,043 mm	Radial clearance, minimum
G _{rmax}	0,12 mm	Radial clearance, maximum

Mounting dimensions

r _{1smin}	1 mm	Edge Spacing
d ₁	66,8 mm	Outer flange diameter inner ring

Temperature range

T _{min}	-60 °C	Operating temperature min.
T _{max}	200 °C	Operating temperature max.



Characteristics



Radial load



Axial load in one direction



Axial load in two directions



Grease Lubrication



Not sealed



Static angular error and misalignment



Dynamic angular error and misalignment